

# OPERATION, SERVICE & PARTS MANUAL SUPPLEMENT

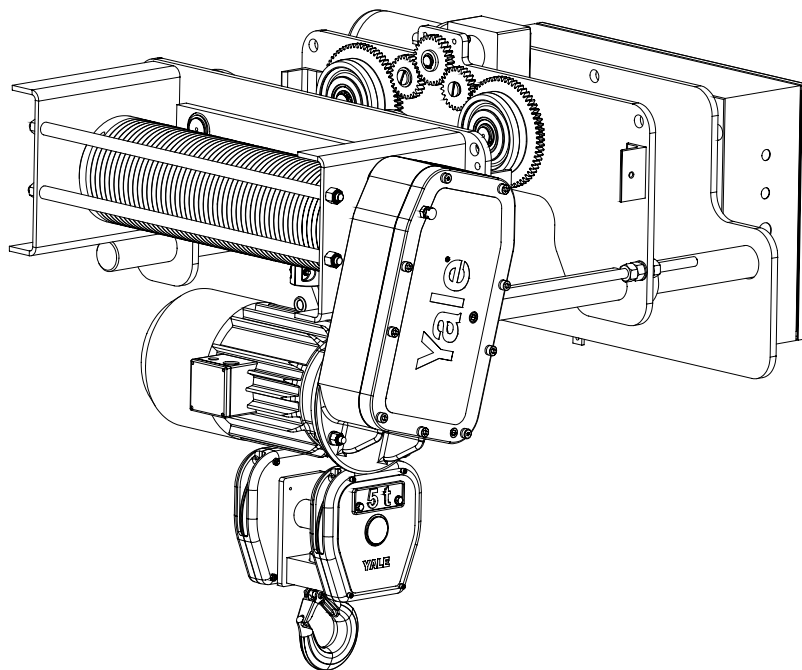

## GLOBAL KING WIRE ROPE HOISTS 5 TONNE 25'-0" LIFT SUPPLEMENT

Before installing hoist, fill in the information below. Refer to the Hoist and Motor data plates.

Model No. \_\_\_\_\_

Serial No. \_\_\_\_\_

Purchase Date \_\_\_\_\_

Voltage \_\_\_\_\_

Rated Load \_\_\_\_\_

**Follow all instructions and warnings for inspecting, maintaining, and operating this hoist.** The use of any hoist presents some risk of personal injury or property damage. That risk is greatly increased if proper instructions and warnings are not followed. Before using this hoist, each operator should become thoroughly familiar with all warnings, instructions, and recommendations in this manual. **Retain this manual for future reference and use.**

Forward this manual to operator. Failure to operate equipment as directed in manual may cause injury.

# Yale<sup>®</sup>

**SIEVERT  
CRANE & HOIST**  
DIVISION OF SIEVERT ELECTRIC  
**Authorized Sales and Service**  
(708) 771-1600  
[parts@sievertelectric.com](mailto:parts@sievertelectric.com)  
[www.sievertcrane.com](http://www.sievertcrane.com)

PRINTED IN U.S.A.

## FOREWARD

This supplement for 25'-0" Lift "B" Frame Global King Hoists is to be used in conjunction with manual 11353394 Revision D. For all "C" Frame Global King Hoists and "B" Frame 40'-0" Lift Hoists refer only to Operation, Service & Parts Manual 11353395 Revision D.

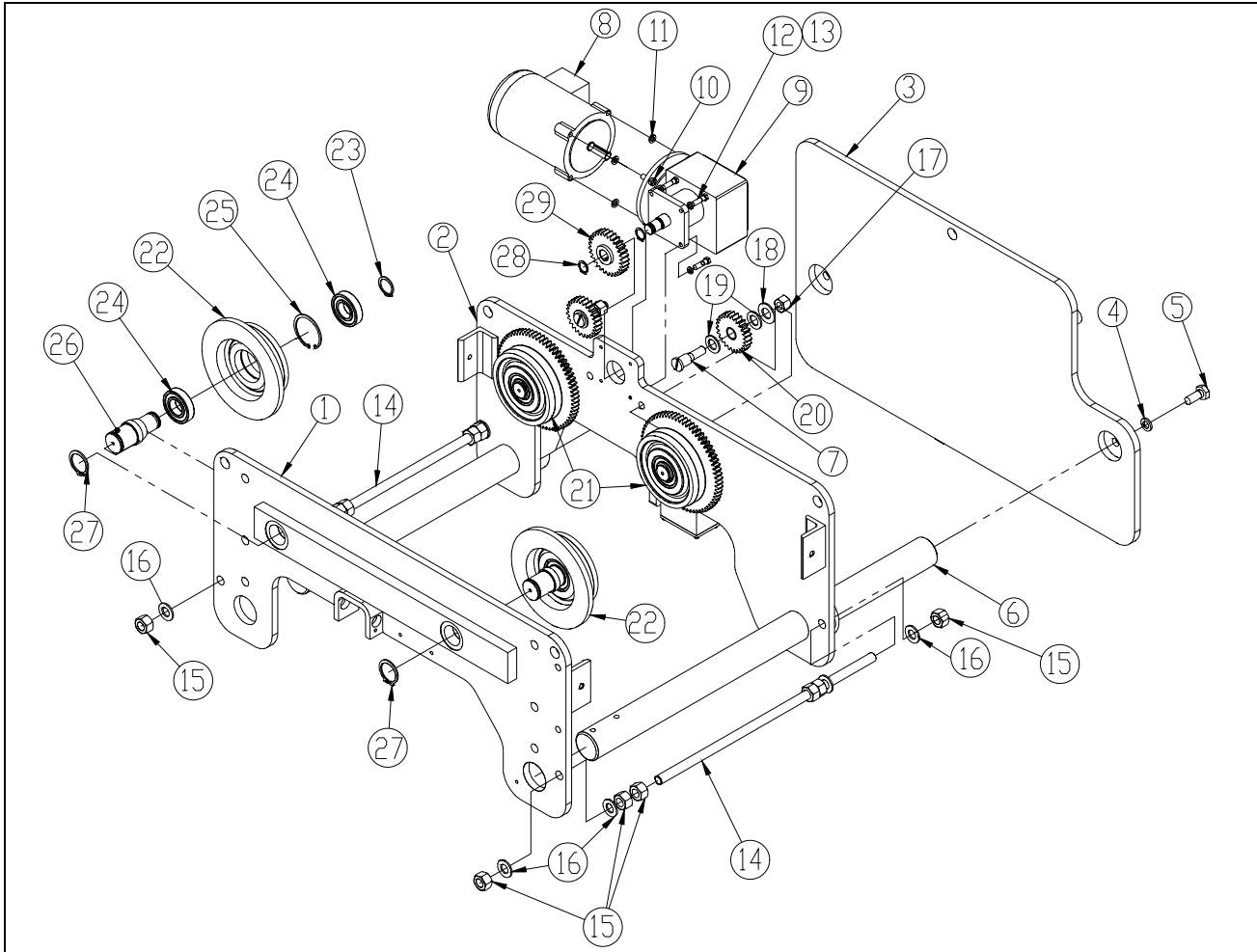

**Figure 9-3a. Motor Driven Trolley Frame – 25'-0" Lift "B" Frame**

"B" Frame (25'-0" Lift): Trolley Frame and Drive Components for Figure 9-3a.			
Ref. No.	Part Number	Description	Qty. Req'd
1	GHB-351A	Side Plate, Drum Side – 25' Lift Frame	1
2	GHB-352A	Side Plate, Drive Side – 25' Lift Frame	1
3	GHB-353A	Counterweight, 25' Lift Frame	1
4	GHB-304	Lock Washer (5/8)	2
5	GHB-305	Hex Head Bolt, Grade 5 (5/8-11 x 1 1/2)	2
6	-	Alignment Bar	2
	GHB-306A	Alignment Bar, 4" Thru 14" Trolley Beam Flange Width	
	GHB-306B	Alignment Bar, 14 1/8" Thru 20" Trolley Beam Flange Width	
7	GHB-357	Hex Cross Shaft	2
8	GHB-308	Motor (Specify HP, Phase, Voltage, Frequency, & Number of Speeds)	1
9	-	Traverse Gear Reducer	1
	GHB-359A	50 FPM	
	GHB-359B	75 FPM	
10	GHB-310	Hex Head Bolt, Grade 5 (3/8-16 x 1)	4
11	GHB-311	Lock Washer (3/8)	4
12	GHB-362	Hex Head Bolt, Grade 5 (5/16-18 x 1 1/4)	4
13	GHB-313	Lock Washer, (5/16)	4

<b>"B" Frame (25'-0" Lift): Trolley Frame and Drive Components for Figure 9-3a.</b>			
<b>Ref. No.</b>	<b>Part Number</b>	<b>Description</b>	<b>Qty. Req'd</b>
14	-	Threaded Rod	2
	GHB-314A	Threaded Rod, 4" Thru 14" Trolley Beam Flange Width	
	GHB-314B	Threaded Rod, 14 1/8" Thru 20" Trolley Beam Flange Width	
15	GHB-315	Heavy Hex Nut (3/4-10)	12
16	GHB-316	Flat Washer (3/4)	8
17	GHB-367	Heavy Hex Lock Nut (5/8-11)	2
18	GHB-368	Flat Washer (5/8)	2
19	GHB-369	Bronze Washer	4
20	GHB-370	Idler Pinion	2
21	GHB-321	Driver Wheel (6 1/2" Diameter Tread)	2
22	GHB-322	Trailer Wheel (6 1/2" Diameter Tread)	2
23	GHB-323	External Retaining Ring	4
24	GHB-324	Ball Bearing	8
25	GHB-325	Internal Retaining Ring	4
26	GHB-326	Axle	4
27	GHB-327	External Retaining Ring	4
28	GHB-378	External Retaining Ring	2
29	GHB-379	Drive Pinion	1

### **5-11. INSPECTION OF TRAVERSE DRIVE. (25'-0" Lift "B".)**

- a) General. The traverse drive consists of four single flange wheels, two on each side of the beam, carried directly by the hoist frame. These wheels rotate on sealed ball bearings supported by fixed pins. Pinions drive two idler pinions that in turn drive wheels with gear teeth cut into the flange. The drive shaft passes through one hoist side and is driven by a single reduction solid shaft gear reducer.
- b) Ensure that the hoist is properly fitted to the beam. The hoist must be centered on the beam with clearance between the sides of the bottom of the beam flange and the inside faces of the wheel flanges. Proper clearance must exist along the entire length of beam that the hoist can traverse. An amount of 3/32 to 1/8 inch clearance per side is recommended for a total of 3/16 to 1/4 inch wider than the beam flange. If too little or too much clearance is determined, adjust trolley per Section II, Paragraph 2-2.
- c) Inspect wheel treads, flanges, and gear teeth for wear. Check for adequate lubrication (**WG**, Section IV, Paragraph 4-7)
- d) Examine the drive pinion, idler pinions, and idler pinion bushings. Check pinions for gear tooth wear and proper alignment with wheel gear. Bronze washers may need to be replaced idler pinions are misaligned. Idler pinions must be replaced as sets and should be replaced along with the drive wheels and drive pinion.
- e) Inspect the traverse gearbox and motor. Look for signs of rough operation, mechanical damage or lubricant leaks. Verify that the four bolts that hold the gearbox to the trolley frame and the four bolts that hold traverse motor to the gearbox are all present and tight. Replace and tighten as necessary. The factory recommends complete replacement of the traverse gearbox. However, gearbox service may be available from you local authorized YALE repair center.



Note: When ordering parts always furnish Hoist Serial Number, Catalog Number, Motor Horsepower, Voltage, Phase, Frequency and Rated Load of Hoist on which the parts are to be used.

Parts for your hoist are available from your local authorized YALE repair station. For the location of your nearest repair station, write:

Yale•Lift-Tech  
414 West Broadway Avenue  
P.O. Box 0769  
Muskegon, Michigan 49443-0769

Phone: (800) 999-6318  
Fax: (800) 742-9270

## WARRANTY

### *WARRANTY AND LIMITATION OF REMEDY AND LIABILITY*

A. Seller warrants that its products and parts, when shipped, and its work (including installation, construction and start-up), when performed, will meet applicable specifications, will be of good quality and will be free from defects in material and workmanship. All claims for defective products or parts under this warranty must be made in writing immediately upon discovery and, in any event, within two (2) years (or as otherwise provided) from shipment of the applicable item unless Seller specifically assumes installation, construction or start-up responsibility. All claims for defective products or parts when Seller specifically assumes installation, construction or start-up responsibility, and all claims for defective work must be made in writing immediately upon discovery and, in any event, within two (2) years (or as otherwise provided) from completion of the applicable work by Seller, provided, however, all claims for defective products and parts must be made in writing no later than thirty (30) months after shipment. Defective items must be held for Seller's inspection and returned to the original f.o.b. point upon request. **THE FOREGOING IS EXPRESSLY IN LIEU OF ALL OTHER WARRANTIES WHATSOEVER, EXPRESS, IMPLIED AND STATUTORY, INCLUDING, WITHOUT LIMITATION, THE IMPLIED WARRANTIES OF MERCHANTABILITY AND FITNESS.**

B. Upon Buyer's submission of a claim as provided above and its substantiation, Seller shall, at its option, either (i) repair or replace its product, part or work at either the original f.o.b. point of delivery or at Seller's authorized service station nearest Buyer or (ii) refund an equitable portion of the purchase price.

C. This warranty is contingent upon Buyer's proper maintenance and care of Seller's products, and does not extend to normal wear and tear. Seller reserves the right to void warranty in event of Buyer's use of inappropriate materials in the course of repair or maintenance, or if Seller's products have been dismantled prior to submission to Seller for warranty inspection.

D. The foregoing is Seller's only obligation and Buyer's exclusive remedy for breach of warranty, and is Buyer's exclusive remedy hereunder by way of breach of contract, tort, strict liability or otherwise. In no event shall Buyer be entitled to or Seller liable for incidental or consequential damages. Any action for breach of this warranty must be commenced within two (2) years (or as otherwise provided) after the cause of action has accrued.